



Name: JOSEMIGUEL SANCHEZ
Date: 06/05/2018
Track: CAMP. ESPAÑA B LA CARLOTA

Track conditions
 Size: Open Med. Tight
 Traction: High Med. Low
 Surface: Smooth Med. Bumpy

Result
 Race time / Lap: _____
 Best lap (1Lap): 26,999

Front suspension

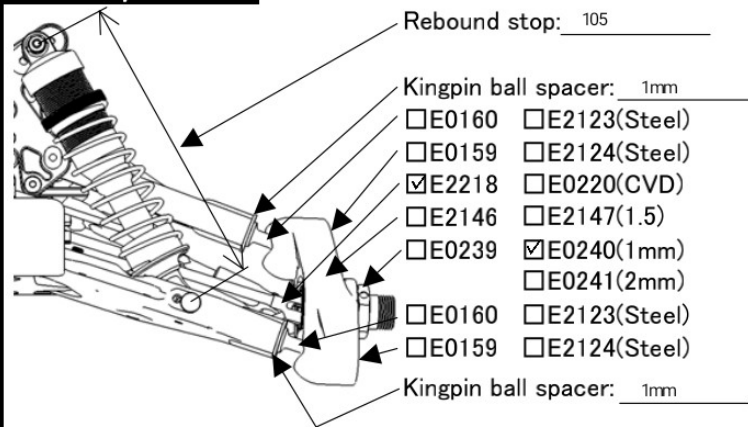

Ride height: 24mm
 Toe angle: _____
 Lower arm plate:
 E2144A,B
 E2154(CFRP 1mm)
 E2155(CFRP 1.2mm)
 Anti roll bar: 23
 Upper arm spacer: 2mm
 Lower arm spacer: 0

Front shocks

Piston: UR 1711 Oil: UR 550
 Spring: 9.0
 Shock position:

 Pivot ball position: Front Rear
 Damper stay: E2562(Aluminum)
 E2565(CFRP)

Steering ackerman

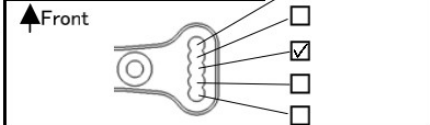

Upper arm position:

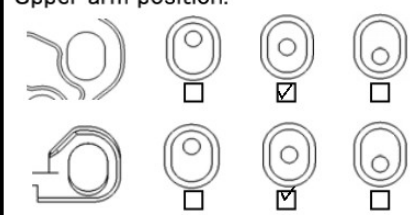

Lower arm position (Kick up):

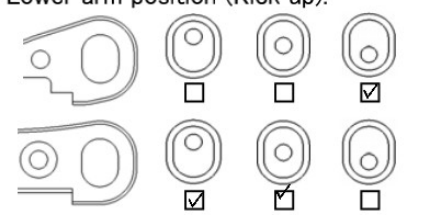

Front upper plate

E2148D E2158(CFRP)

Servo saver arm

E2301A E2310(Aluminum)

Rear suspension

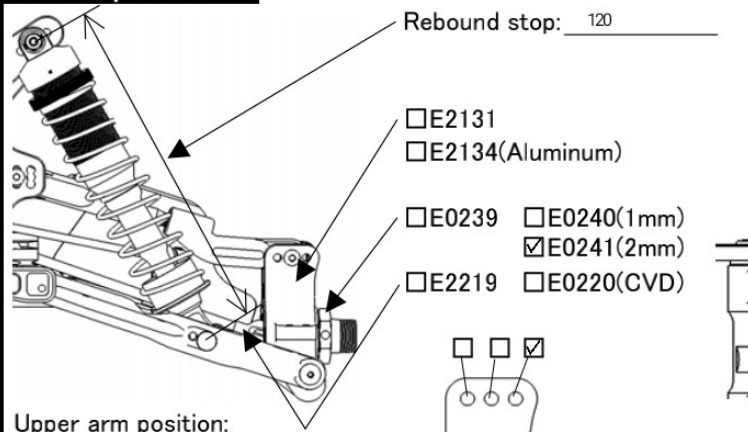

Ride height: 25mm
 Camber angle: _____
 Lower arm plate:
 E2145A,B
 E2156(CFRP 1mm)
 E2157(CFRP 1.2mm)
 Anti roll bar: 27
 Lower arm spacer: 1mm
 Upright spacer: 1mm

Rear shocks

Piston: UR 1712 Oil: UR 550
 Spring: 10,75
 Shock position:

 Pivot ball position: Front Rear
 Damper stay: E2563(Aluminum)
 E2566(CFRP)

Center shaft

E0223,E0259 E2228,E2229

Tension rod

Front: E2107A(Long) E2107B(Short)
 Rear: E2148C E0803(Rubber)

Upper arm position:

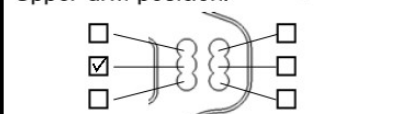

Lower arm position (Toe angle):

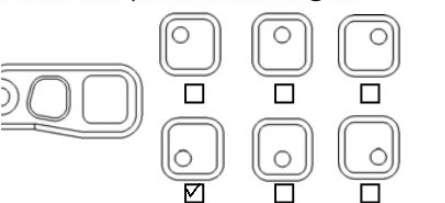

Lower arm position (Anti-squat):

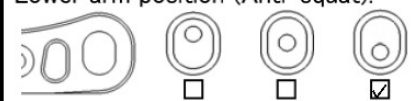

Weight

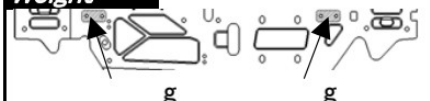

Engine
 Type: PROTUNED M3T Plug: P3 Reducer: _____
 Muffler: ULTIMATE2141 Fuel: NITROLUX FUEL Gasket: _____
 Engine mount: E0701(Standard) Other _____

Diff. Gear
 Oil
 Front: 44/13T 42/12T 5000
 Rear: 44/13T 42/12T 3000
 Center: 44T 46T 6000
 47T 48T

Tires
Front
 Type: PROCIRCUIT ADDICTIVE
 Compound: P2
 Inserts: XL
 Wheel: PROCIRCUIT VORTEX
Rear
 Type: PROCIRCUIT ADDICTIVE
 Compound: P2
 Inserts: XL
 Wheel: PROCIRCUIT VORTEX

Clutch 3P 4P
 Clutch bell: 13T 14T
 Clutch shoes C0754 E0704 E0710 E2706
 Clutch spring 0.8 0.9 0.95 1.0 1.05 1.1

Body/Wing

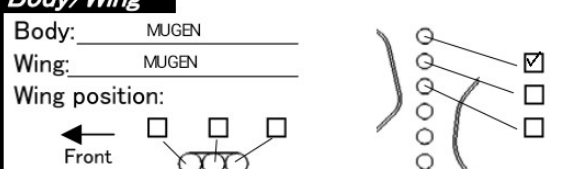

Comments HEVOS MONTADO LOS NUEVOS PISTONES ULTIMATE EN LOS AMORTIGUADORES
 DE 8X1,2 DELANTE Y 8X1,3 DETRAS.